



**CycleSafe**<sup>®</sup>  
SECURE BICYCLE PARKING

# *Vintage Racks*<sup>™</sup> by: **cycle-safe**



*The Paris*

*The charm of yesteryear.  
The performance of tomorrow.*

Vintage Racks by Cycle-Safe are a novel blend of the old and the new. They capture the charm of traditional ornamental bicycle stands. Yet they incorporate leading-edge technologies to meet contemporary performance standards.



*The Plymouth*

Vintage Racks were developed in response to urban planners' efforts to recreate historic streetscapes as counterpoints to the hustle and bustle of the modern world. Vintage Racks perfectly complement these restoration projects - both as decorative art pieces and as a means to encourage and accommodate eco-friendly transportation.



*The Lafayette*

## THE PEARL

In-ground Rack # 12180G  
Surface-Mount # 12180S



# Vintage Racks™

by: **cycle-safe**

*From the leader in secure bicycle parking.*

For more than 20 years, Cycle-Safe has revolutionized bicycle parking with breakthrough designs, materials and technologies. Cycle-Safe installations are located worldwide, on city streets and university campuses, in office parks and shopping centers, at park & ride lots, and more. For variety, longevity and dependability, Cycle-Safe has no equal.

## THE PLYMOUTH

In-ground Rack # 12140G  
Surface-Mount # 12140S

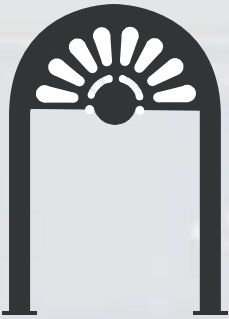

*Superior design for better safety.*

The inverted U is the most universally acknowledged design for efficient bicycle racks. Cycle-Safe Vintage Racks offer superior cycle frame support and stability characteristic of this design. The smooth lines of Cycle-Safe's one-bend U racks are also safer for pedestrian traffic around bike parking.



**THE PLYMOUTH**  
Surface Mount # 12140S

## THE MADISON

In-ground Rack # 12130G  
Surface-Mount # 12130S



*Durable and maintenance-free.*

Cycle-Safe Vintage Racks are completely covered with TGIC Polyester powder coat with E-coat primer over Schedule 40 steel pressure pipe. This ensures maximum corrosion-resistance, impact-resistance, and UV stability to provide a maintenance free finish.

## THE LAFAYETTE

In-ground Rack # 12150G  
Surface-Mount # 12150S

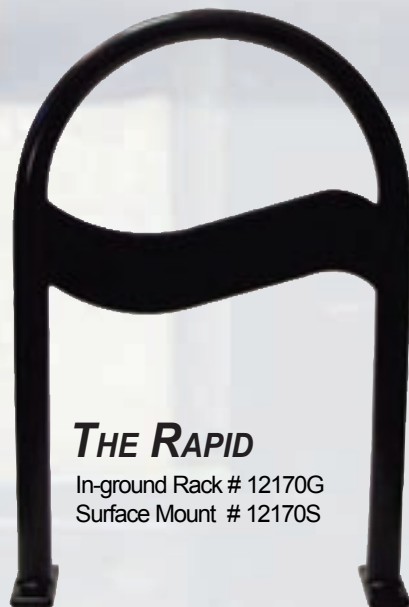
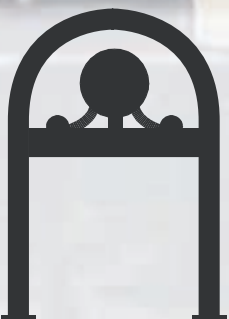

## THE RAPID

In-ground Rack # 12170G  
Surface Mount # 12170S

### In-ground Installation

This is the standard for new construction and the most secure type of inverted-U installation. Can easily be installed in existing locations by drilling a 3"-4" core and grouting.

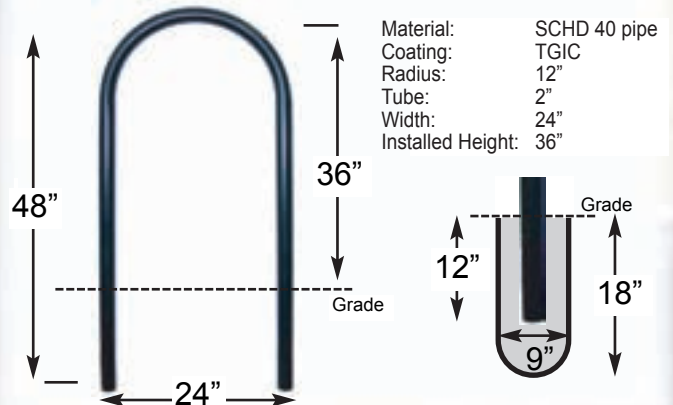

To download product specifications  
go to [cyclesafe.com](http://cyclesafe.com)  
or call 888-950-6531

**THE PARIS**  
In-ground Rack # 12193G  
Surface-Mount # 12193S

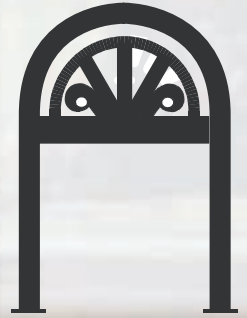

- Unique Vintage Designs
- Low minimums to order (qty. 6)
- No Custom Set-ups
- Maintenance-free coating
- Meets all industry standards
- Capacity is 2 bicycles per rack

**THE BRETON**

In-ground Rack # 12133G  
Surface-Mount # 12133S

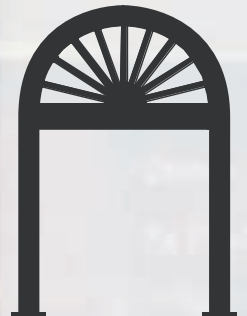

**THE FULTON**

In-ground Rack # 12190G  
Surface-Mount # 12190S



**THE CASCADE**

In-ground Rack # 12160G  
Surface-Mount # 12160S



In-ground  
Racks

*A pleasure to behold.*

Originally designed for historic restoration projects, Cycle-Safe Vintage Racks are now being used as functional art in all manner of urban landscapes. Custom racks (see back page) provide even greater aesthetic flexibility. Custom colors are also available. All these rack choices may qualify for "1% for Art" public funding.



Surface-Mount  
# 12160S



Rail-Mount  
# 12150S  
# 12170S  
# 12140S

Rails can be obtained in 6 ft. and 12 ft. length and are fully coated.



**Surface-Mount**  
3/8" Steel Plate  
5/8" Holes  
4.5" centers



**A**

**Surface Mount Options**

**NEW EXCLUSIVE!** Our recommended **(A)** Item # 12718, 3/8" x 4" Torx Tamper-resistant button head concrete screw.



**THE PARIS**  
Surface Mount # 12193S

# Cycle-Safe Maintenance-Free One-Bend Bike Racks

## CUSTOM RACKS

by: *cycle-safe*



Turn your bike rack into a promotion with our exclusive racks. Display your corporate or community logo with laser-cut stainless steel made to your specifications, or use screen-printed images. Call for details on custom racks.



Cycle-Safe bicycle racks are designed to provide safety for users and to encourage cycling. The Cycle-Safe engineering team has developed three variations for installation to accommodate your needs; In-ground, Surface-Mount, or Rail-Mount.

Visit our Web site for custom images... [cyclesafe.com](http://cyclesafe.com)

### How to Specify Bicycle Racks

Bicycle rack part # \_\_\_\_\_ (add Vintage style part#), as manufactured by Cycle-Safe, Inc., 888-950-6531. There is no equal.

#### Furnished Material Shall be:

- 1-1/2" SCHD, 40 PIPE (1.50" I.D.), rolled in the shape of an inverted "U" to a 12" outside radius standing 36" high.
- Vintage inlay design to be 1/4 steel plate, laser-cut.
- Coating to be TGIC Polyester powder coat.
- Standard Color – Black.
- Texture – regular grain.
- Gloss – semi-gloss.
- Tensile Strength – 1800 PSI min.
- Resistance to abrasion.
- Salt Spray Resistance to >2000 hours
- Hardness (Shore D) ASTMD 2240 - Results 52.
- Installation Options: In-ground (G), Surface-mount (S), Rail-mount (R)

### Installation Layouts & Space Requirements:

Based on recommendations from the Association of Pedestrian and Bicycle Professionals the following diagrams show typical configurations and space allowances for installations of multiple parking bicycle racks.

### Spacing

A rack area or "bicycle parking lot" is an area where more than one rack is installed. Aisles separate the racks. The aisle is measured from tip to tip of bike tires across the space between racks. The minimum separation between aisles should be 48 inches to provide enough space for one person to park one bike. In high traffic areas, recommended minimum aisle width is 72 inches. Six feet of depth should be allowed for each row of parked bicycles. Conventional bicycles are just less than 72 inches long and can easily be accommodated in that space.

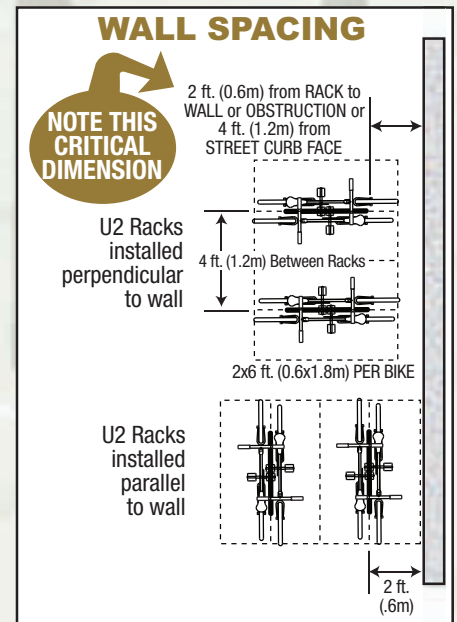

*Vintage Bike Rack Series protected under US/Canadian Design Patents and Patents Pending.*

Download complete specifications for each rack in Word format from our web site [cyclesafe.com](http://cyclesafe.com)



Cycle-Safe, Inc. also manufactures bike lockers and a wide range of bicycle locker accessories. Please call or visit our web site [cyclesafe.com](http://cyclesafe.com) for details.

947 Forest Hill Ave. Suite C  
Grand Rapids, MI 49546  
888-950-6531 • Fax: (616) 954-0290

E-mail: [info@cyclesafe.com](mailto:info@cyclesafe.com) • Website: [cyclesafe.com](http://cyclesafe.com)